

MCA15RCY is a 15 cm (5") cone driver, developed for use as a high quality midrange unit.

Classically coated paper cone gives a smooth extended frequency response with a controlled roll off. The large magnet system, together with the light cone give high sensitivity with low distortion and good transient response.

Extremely stiff and stable injection moulded metal basket keeps the critical components in perfect alignment. Large windows in the basket both above and below the spider reduce sound reflection, air flow noise and cavity resonance to a minimum.

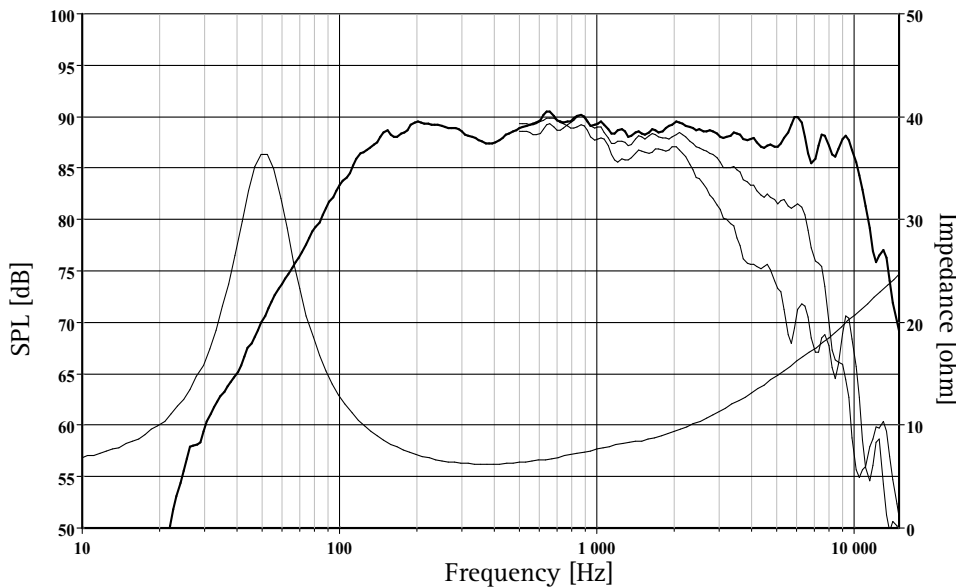

The frequency responses above show measured free field sound pressure in 0, 30, and 60 degrees angle using a 20L closed box. Input 2.83 V_{RMS}, microphone distance 0.5m, normalized to SPL 1m. The dotted line is a calculated response in infinite baffle based on the parameters given for this specific driver. The impedance is measured in free air without baffle using a 2V sine signal.

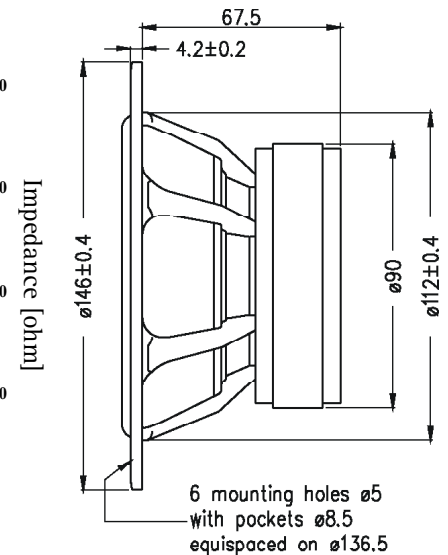

Nominal Impedance	8 Ohms	Voice Coil Resistance	5.8 Ohms
Recommended Frequency Range	100 - 4000 Hz	Voice Coil Inductance	0.73 mH
Short Therm Power Handling *	300 W	Force Factor	6.8 N/A
Long Therm Power Handling *	100 W	Free Air Resonance	51 Hz
Characteristic Sensitivity (2,83V, 1m)	89.5 dB	Moving Mass	7.1 g
Voice Coil Diameter	26 mm	Air Load Mass In IEC Baffle	0.42 g
Voice Coil Height	9.4 mm	Suspension Compliance	1.4 mm/N
Air Gap Height	6.0 mm	Suspension Mechanical Resistance	1.53 Ns/m
Linear Coil Travel (p-p)	3.4 mm	Effective Piston Area	80 cm ²
Maximum Coil Travel (p-p)	14 mm	VAS	12 Litres
Magnetic Gap Flux Density	1.25 T	QMS	1.57
Magnet Weight	0.42 kg	QES	0.30
Total Weight	1.3 kg	QTS	0.25